

Technical Data

PGCLS880



CUMMINS Engine: KTA38-G2A Electronic Governor	Alternator Leroy-somer : LSA49.1L11	Generator Model:	PGCLS880 (Open)
			PGCLS880 (Silent)

60Hz 1800 r.p.m	3 Phase 4 Wires	Power Factor: Cos ϕ = 0.8	Emissions Certification:	N/A
--------------------	--------------------	-----------------------------------	-----------------------------	-----

RATINGS	Prime Power		Standby Power		Rated Current	
	(PRP)		(LTP)		(A)	
Voltage (V)	kW	kVA	kW	kVA	Amps	
480/277	800	1000	880	1100	1202.8	
440/254	800	1000	880	1100	1312.2	
416/240	800	1000	880	1100	1387.9	
240/138	800	1000	880	1100	2405.7	
220/127	800	1000	880	1100	2624.4	

RATINGS:

All three Phase generator sets are rated at 0.8 power factor. All single-phase generator sets are rated at 0.8 or 1.0 power factor. **PowerGen** reserves the right to change the design or specifications without notice and without any obligation or liability whatsoever.

Prime Power:

Available continuously at variable load in lieu of commercially purchased power for an unlimited number of hours per year in accordance with ISO8528-1, and an overload of 10% permitted for one hour in every twelve hours of operation in accordance with ISO 3046-1.

Standby Power:

Emergency Standby Power in variable load applications in accordance with ISO8528-1 in the event of a utility power failure. No overload available for this service as relevant alternators are peak continuous rated at 27°C.

Standard Features

- ▲ High efficient water cooled diesel engine
- ▲ Brushless alternators (Class H, with AVR.)
- ▲ Heavy duty rubber anti-vibration mountings
- ▲ 12/24V starter batteries and connecting cables
- ▲ Separate engine-drive battery charging alternator
- ▲ Industrial silencer for open type generator sets
- ▲ Residential silencer for open type generator sets
- ▲ Auto start / Digital Tide Easycon Control Panel
- ▲ Wiring with IEC standard
- ▲ Factory Test Certificate
- ▲ Operation & Maintenance Manual & Diagrams
- ▲ Worldwide Product / Technical Support
- ▲ Radiator with cap and drain point.
- ▲ Fully guarded engine driven fan
 - ▲ No MCCB
- ▲ Oil filter - Diesel filter - Air filter
- ▲ Fully welded steel baseframe with lifting and fork-lifting facilities.
 - ▲ Sound proof & Weather protective enclosures for silent type generator sets.

Optional

- △ Automatic Transfer Switch (ATS)
- △ Water - fuel separator
- △ Water heater for severe cold weather
- △ Lub-oil heater for severe cold weather
- △ 50°C-60°C Radiator
- △ Dual wall fuel tank base
- △ Fuel level sensor
- △ Maintenance free battery
- △ Extra air filters for time-maintenance
- △ Extra diesel filters for time-maintenance
- △ Extra oil filters for time-maintenance
- △ Separated standing fuel tank
- △ Low coolant level sensor
 - △ Full range of attachments and options available for alternator
 - △ ACB

△ Additional CE Features Selection **Overall Dimensions (mm) & Weight (kg)**

Open Type

Length:

4300

Width:

1700

Height:

2400

Weight:

8200

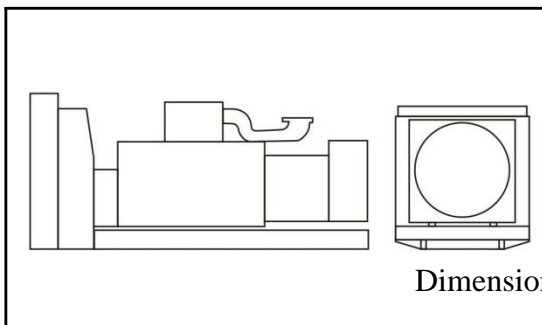

Silent Type

Length:

6058

Width:

2438

Height:

2591

Weight:

11500

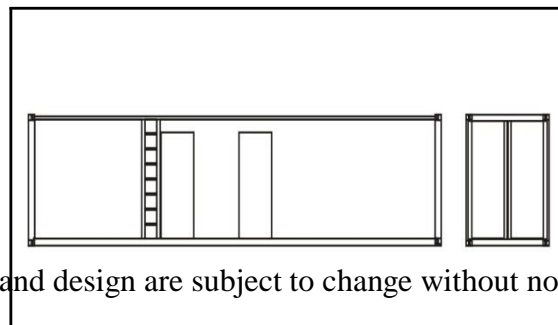

Dimension and design are subject to change without notice.

Warranty

The goods of PowerGen System are under warranty against defects in materials and workmanship for a period of 12 months or 1000 hours whichever come first from the date

of delivery to the end user (except the damageable spare parts of genset caused by incorrect man-made operation), and that the aforementioned warranty for the same token is back up by the engine & alternator manufactures and their global distributors.

Engine Specification

General Performance	
Manufacture	CCEC Cummins
Engine Model	KTA38-G2A
Engine Type	4 Cycle, V 60°, 12 Cylinder
Engine Speed	1800 r.p.m
Base Output Power	915kW/1227hp
Standby Power	1007kW/1350hp
Governor Type	Electronic
Air Intake Way	Turbocharged & Aftercooled
Displacement	37.8L
Cylinder Bore * Stroke	159mm × 159mm
NO. of Cylinders	12
Compression Ratio	14.5:1
Engine Idle Speed	725-775 r/min
Piston Speed	9.5 m/s
Intake Air Flow	1369 Litres/sec.
Air Clearner Type	Dry

Exhaust System	
Exhaust Gas Flow	3679 Litres/sec.
Exhaust Gas Temperature	485 - 502°C
Maximum Back Pressure	10kPa
Exhaust Pipe Size	152mm

Air Intake System	
Recommended intake piping size	N/A
Maximum Intake Air Restriction	
- Dirty Element	6.25kPa
- Clean Element	3.73kPa

Lubrication System	
Oil Pan Capacity (High-Low)	114-87 Litres
Maximum Oil Temperature	121°C
Maximum Oil Consumption	N/A
Total System Capacity Including Bypass Filter	135 Litres

Fuel System	
Type Injection System	Direct Injection Cummins PT
Fuel Consumption at 100% Standby power	247 Litres/hour
Fuel Consumption at 100% Prime power	225 Litres/hour
Fuel Consumption at 75% Prime power	164 Litres/hour
Fuel Consumption at 50% Prime power	111 Litres/hour
Fuel Consumption at 25% Prime power	55 Litres/hour
Fuel Tank Capacity	
- Open Type Genset	N/A
- Silent Type Gensets	N/A

Cooling System	
Coolant Capacity - Engine Only	118 Litres
Standard Thermostat (Modulating) Range	82 - 93°C
Maximum Top Tank Temperature	
- Standby Power	104°C
- Prime Power	100°C

Electric System	
Electrical System Voltage	24V
Battery	Maintenance-free
Connecting Cables	Available

Thermal	
Radiated Heat to Ambient	123-136kW
Heat Rejection to Coolant	496-548kW
Heat Rejection to Exhaust	681-738kW

Alternator Specification

General Data	
Manufacture / Brand	Leroy-somer
Model	LSA49.1L11
AVR Model	R450
Coupling / Bearing	Direct / Single Bearing
Phase	3 Phase
Power Factor	Cos φ = 0.8
Winding pitch - Code	2/3 - (N° 6)
Drip Proof	IP 23
Excitation	AREP or P MG

60HZ/1800R.P.M	
Prime Output Power	816kW/1020kVA
Standby Output Power	898kW/1122kVA
Insulation class	H
Voltage regulation	± 0,5 %
Total harmonic TGH / THC	at no load <4% - on load <4%
Wave form : NEMA = TIF - (*)	< 50
Wave form : I.E.C. = THF - (*)	< 2 %
Altitude	≤ 1000 m
Overspeed	2250 min -1