

PGCLS500KW

60Hz/1800 r.p.m-P.F.0.8					Prime Power	Standby Power	Rated Current
Genset	Engine	Alternator	Voltage (V)	PH	kW/kVA	kW/kVA	Amps
FC562X-C	KTA19-G3A	LSA47.2M7 HCI544D FPA35-4303	380/220	3	450/562	500/625	854.7
		LSA47.2M7 HCI544D FPA35-4002	208/120	3	450/562	500/625	1561.4
		LSA47.2M7 HCI544D FPA35-4002	220/127	3	450/562	500/625	1476.2
		LSA47.2M7 HCI544C FPA35-4002	230/132	3	450/562	500/625	1412.0
		LSA47.2S5 HCI544C FPA35-4002	480/277	3	450/562	500/625	676.6

Ratings: All three Phase generator sets are rated at 0.8 power factor. All single-phase generator sets are rated at 0.8 or 1.0 power factor. POWERGEN reserves the right to change the design or specifications without notice and without any obligation or liability whatsoever.

Prime Power:

Available continuously at variable load in lieu of commercially purchased power for an unlimited number of hours per year in accordance with ISO8528-1, and an overload of 10% permitted for one hour in every twelve hours of operation in accordance with ISO 3046-1.

Standby Power:

Emergency Standby Power in variable load applications in accordance with ISO8528-1 in the event of a utility power failure. No overload available for this service as relevant alternators are peak continuous rated at 27°C.

Overall Dimensions (mm) & Weight (kg)

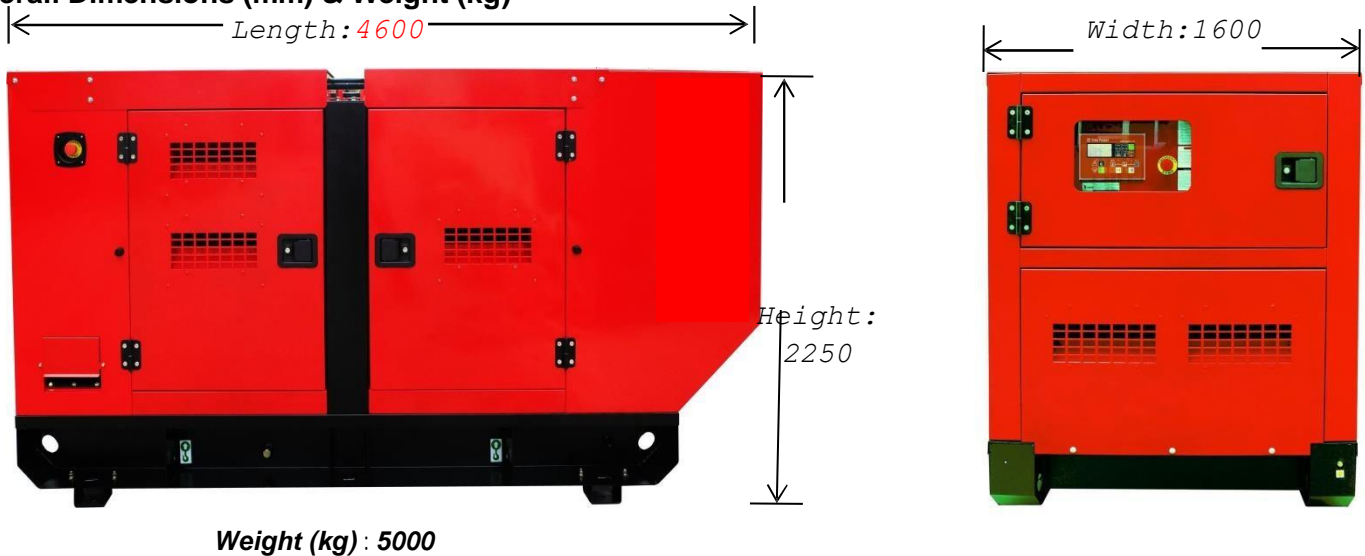

Standard and optional accessories

System	Standard ●	Optional ○
Air Intake System	<ul style="list-style-type: none"> ● Standard air filter ● Air filter overload alarm 	<ul style="list-style-type: none"> ○ Air prefilter ○ Heavy air filter
Cooling System	<ul style="list-style-type: none"> ● 50°C radiator ● Low water level alarm ● Fan and belt guard 	<ul style="list-style-type: none"> ○ Antifreeze ○ Water jacket heater
Exhaust System	<ul style="list-style-type: none"> ● Discharge valve ● Stainless steel bellow ● Residential silencer ● Complete exhaust pipe ● Rain cap 	<ul style="list-style-type: none"> ○ Stainless steel silencer ○ Stainless steel exhaust pipe
Fuel System	<ul style="list-style-type: none"> ● 8 Hours integrated base fuel tank ● Standard fuel filter ● Fuel level gauge ● Fuel filling cap 	<ul style="list-style-type: none"> ○ 6 Hours double wall base fuel tank ○ Fuel-water separator ○ Oil level sensor ① ② ○ Automatic fuel top up system ①
Lubrication System	<ul style="list-style-type: none"> ● Fuel hose ● Standard oil filter ● Manual oil pump and drain 	<ul style="list-style-type: none"> ○ Oil heater ○ Lube oil level indicator
Alternator and Electric Switch	<ul style="list-style-type: none"> ● Shunt or self excited ● Class H insulation ● H class temperature rise ● DELIXI MCCB ● Terminal connection lugs (L1, L2, L3, LN) 	<ul style="list-style-type: none"> ○ Oil temperature indicator ① ○ PMG or AREP (Leroy-Somer only) ○ Alternator space heaters ○ PT100 winding temperature sensors ○ Weaver AVR ○ Weaver prolapse transformer <ul style="list-style-type: none"> ○ F class temperature rise ○ 4 Pole circuit breaker with leakage protection ○ Circuit breaker - 4 pole <ul style="list-style-type: none"> ○ ABB MCCB ○ MCCB auxiliary contact and shunt tripping device
Control System	<ul style="list-style-type: none"> ● Comap Nano Plus for 4 cylinders engine ● Comap Intelilite AMF20 for 6 cylinders or ECU engine 	<ul style="list-style-type: none"> ○ Panel lighting
Silent / Base	<ul style="list-style-type: none"> ● 67-72 db(A) @ 3 meters ● 4mm -6mm Steel base ● Transportation support leg ● Single hook ● Power coating enclosure ● Anti-vibration mounting between engine /alternator and baseframe ● Emergency stop mounted outside the 	<ul style="list-style-type: none"> ○ Forklift holes ○ Enclosure color: ○ Trailer for off road or on road
Start / Charge	<ul style="list-style-type: none"> ● canopy ● Standard color: Ral 3020 ● Battery with bracket and cables 	<ul style="list-style-type: none"> ○ Low temperature starting batteries
Remark:	<ul style="list-style-type: none"> ● Engine battery charger ● 3A Mains charger 	<ul style="list-style-type: none"> ○ Battery switch ○ High current charger (10A, 20A)

① When you need the automatic oil top up system, you have to use the electrical oil level sensor.

② You can choose either electrical oil level sensor or oil temperature sensor.

Engine

Engine specifications		Lubrication System	
Manufacture	CCEC Cummins	Oil capacity (high - low)	37.9-32.2 Litre
Engine model	KTA19-G3A	Maximum allowable oil temperature	121°C
Engine type	4 cycle, in-line, 6-cylinder	Total System Capacity	
Engine speed	1800 r.p.m	- Sump plus filters	50 Litres
Prime power	507kW/680hp	Fuel System	
Standby power	563kW/755hp	Type injection system	Direct injection cummins PT
Governor type	Electronic	Minimum Allowable Fuel Tank Vent Capabili	425 Litres/hou
Aspiration:	Turbocharged & Aftercooled	Fuel consumption at 100% standby power	131 Litres/hou
Displacement	19L	Fuel consumption at 100% prime power	118 Litres/hou
Bore * Stroke	159mm x 159mm	Fuel consumption at 75% prime power	91 Litres/hou
NO. of cylinders	6	Fuel consumption at 50% prime power	64.2 Litres/hou
Compression ratio	13.9:1	Fuel consumption at 25% prime power	35.6 Litres/hour
Brake mean effective pressure	675-775 r/min	Fuel tank capacity	6 hours
Piston speed	9.5 m/s	Cooling System	
Firing order	1- 5-3 -6 -2 -4	Coolant capacity - engine only	30 Litre
Noise level @7m	78 dBA	Standard thermostat (modulating) range	82 - 93°C
Exhaust System		Maximum allowable top tank temperature	
Maximum back pressure	10 kPa	- Standby power	104 °C
Exhaust pipe size normally acceptable	127 mm	- Prime power	100 °C
Exhaust gas temperature	481-504°C	Electric System	
Exhaust gas flow	1734 Litres/sec.	Electrical system voltage	24V
Air Intake System		Battery	Maintenance-free
Maximum intake air restriction with heavy duty air cleaner		Connecting cables	Available
- Dirty element	6.23 kPa	Thermal Data	
- Clean element	3.73 kPa	Radiated heat to ambient	67-74kW
Recommended intake piping size	N/A	Heat rejection to coolant	283-313kW
Intake air flow	687 Litres/sec.	Heat rejection to exhaust	302-328kW

Alternator

60Hz/1800R.P.M

General Data

Power factor	Cos φ = 0.8
Excitation	Shunt / Brushless

Insulation class	H	H
Bearing		Single
Altitude		≤ 1000 m

Ratings

Prime Power Standby Power

Brand	Alternator	Number of wires	AVR Model	PH	Voltage (V)	kW/kVA	kW/kVA
Leroy-Somer	LSA47.2M7	12	R250			450/562	500/625
Stamford	HCI544D	12	AS440	3	380/220	500/625	538/673
Tide	FPA35-4303	6	SX440			470/588	517/464
Leroy-Somer	LSA47.2M7		R250			488/610	534/668
Stamford	HCI544D	12	AS440	3	208/120	460/575	485/606
Tide	FPA35-4002		SX440			480/600	528/660
Leroy-Somer	LSA47.2M7		R250			500/625	552/690
Stamford	HCI544D	12	AS440	3	220/127	475/594	515/644
Tide	FPA35-4002		SX440			480/600	528/660
Leroy-Somer	LSA47.2M7		R250			500/625	556/695
Stamford	HCI544C	12	AS440	3	230/132	465/581	505/631
Tide	FPA35-4002		SX440			480/600	528/660
Leroy-Somer	LSA47.2S5	12	R250			456/570	500/625
Stamford	HCI544C	12	AS440	3	480/277	475/594	515/644
Tide	FPA35-4002	6	SX440			480/600	528/660



Comap Nano Plus



Comap IntelliLite



Comap IntelliLite AMF25

Viewable parameters	Phase voltage	3	3	3
	Wire voltage	3	3	3
	Current	Instrument	3	3
	Frequency	●	●	●
	Active power	×	●	●
	Reactive power	×	●	●
	Apparent power	×	●	●
	Power factor	×	●	●
	Electric energy metering	×	×	●
Generator protection	Abnormal voltage	●	●	●
	Over-current warning	×	●	● Over
	current protection	×	●	● Over
	Frequency protection	●	●	● Short
	circuit protection	MCCB	MCCB+○	MCCB+○
Engine figure	Oil pressure	●	●	●
	Water temperature	●	●	●
	Fuel level	○	○	○
	Speed	●	●	●
	Battery voltage	●	●	●
	Elapsed time	●	●	● Low
Engine protection	oil pressure warning	●	●	● Low oil
	pressure protection	●	●	● High
	temperature warning	●	●	●
	High temperature protection	●	●	●
	Overspeed warning	●	●	●
	Overspeed protection	●	●	●
	Charge fault	●	●	●
Function	Remote start-stop	●	●	●
	AMF	●	●	●
	Programmable input	3	7	7
	Programmable output	6	7	7
	Port extension	USB	○	○
	Remote monitoring	×	○	○
	Communication port	×	○	○ CAN
	● ○ ● Start/Stop time control			×
	×	● Maintenance tips	×	×
	● Fault record	×	×	●
	Multi-language function	×	●	●
Remark:	● Standard	○ Optional	×	

(Safety Installation: Detect - Control – Switch System)

POWERGEN offers not only a changeover switch but also an integrated mains detection and switch system for your 24 Hour Power Protection. The system enables automatic start-up and operation of the generating set in the event of a mains power failure, overvoltage or loss of phase; and also mains automatic re-transfer once it come back. The system has a wide application such as hospital, bank, telecom, air port, broadcasting station and hotels.

System Advantages

- Automatically transfer and re-transfer load from main power to gen-power without operator intervention operation. (Both automatic and manual)
- ATS Controller (AMF function), seamless integration with Intelligent 5.0
- Available from 32 – 3200A, better protection for 4 pole switch.
- Available in standard, bypass isolation and service-entrance configurations.
- Configurable in open, closed and programmed transition operating modes.
- Designed to interface seamlessly with POWERGEN generators and switchgear.
- Drip Proof IP23 Enclosure.
- Easy Installation: Wall-mounted & Floor standing
- Comes fully loaded with the technology to do the job.



Rated Current	Breaker Type			
	A	Chinese	ABB	Socomec
32	x		B	x
63	A		B	B
80	x		x	B
100	A		B	B
125	x		B	B
160	B		B	B
200	x		B	x
250	C		B	B
300	x		x	x
315	x		C	x
400	C		C	C
630	C		D	D
800	D		D	D
1000	D		D	D
1250	D		D	D
1600	D		D	E
2000	E		E	E
2500	E		E	E
3200	E		x	E

Dimensions : mm

A : 400x200x500

B : 500x300x650

C : 600x400x1200

D : 800x600x1400

E : 1000x800x1600



Controller

StandardParameters

- Gen phase voltage
- Generator frequency
- Engine speed
- Battery voltage
- Engine running hours cou
- Engine temperature
- Oil pressure



WarningandShutdownAlarms

- Low oil pressure
- High engine temperature
- Over speed
- Under speed
- Start failure
- Stop failure
- Emergency stop
- High/low battery voltage
- Aux. shutdown alarm
- Aux. Warning